

Blue Level GmbH
Säntisstrasse 17
CH-8280 Kreuzlingen
Switzerland

Hand-Desinfektionsgerät Wandmontage

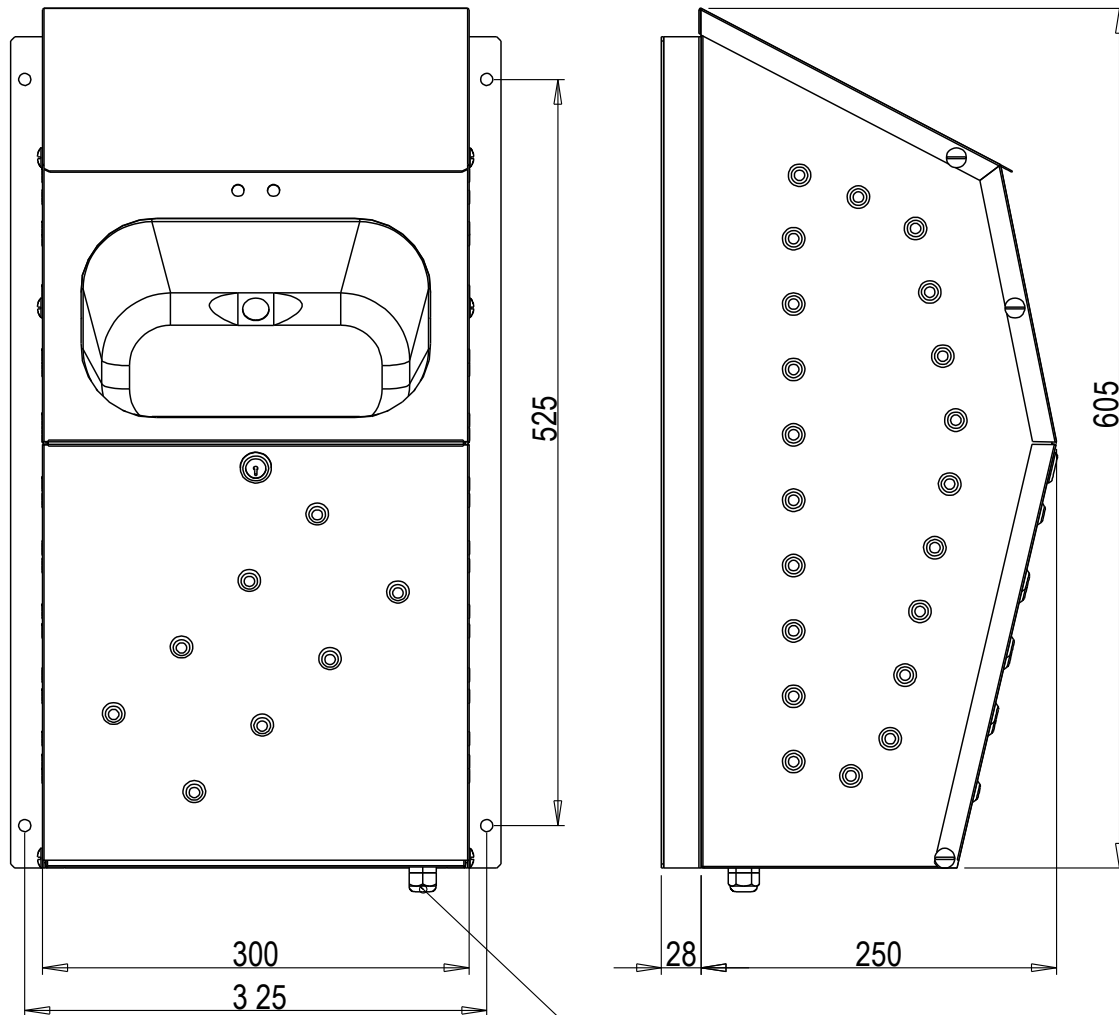

eShop: <http://www.schuhputzmaschine.ch>
eMail: info@bluelevel.ch



1x 230V/N/PE 50Watt
1,5m Schukozuleitung

